

# TELEDYNE ANALYTICAL INSTRUMENTS

## Portable Oxygen Analysis



3110 SERIES • 311 SERIES • TurbO2 SERIES

# PORTABLE OXYGEN ANALYZERS

Analysis of oxygen has become a part of every industry that uses or produces gas or gas mixtures. Teledyne's complete line of portable gas analyzers provides this vital analysis in a compact package operating without an external power source.

Oxygen concentration in the sample gas stream is measured by Teledyne's own advanced Micro-fuel Cell sensor specific to oxygen. The high-accuracy and fast response of these units is ideal for measuring oxygen in hydrogen, nitrogen, argon, helium, acetylene, ethylene, butadiene, carbon dioxide, hydrocarbons and many other gases.

## MAINTENANCE FREE SENSOR

Teledyne's sensors set industry standards for accuracy, sensitivity, and ease of use. Because every sensor undergoes stringent testing and quality control, the end user is assured of outstanding reliability and performance. These patented Micro-fuel Cells are sealed, electrochemical devices with no electrolyte to change or electrodes to clean, making them virtually maintenance free. The sensors are specific to oxygen and are capable of accurately monitoring gas streams containing up to 100% hydrocarbons.

## EASY CALIBRATION

The 311, 3110 and TURBO2 families have a special cal range that allows accurate calibration with the most economical, reliable, abundant standardization gas there is -- atmospheric air. No special span gas is required, and because the sensors offer an absolute zero, there is never a need for a zero gas.

## PRINCIPLE OF ANALYSIS

Oxygen in the sample diffuses into the Micro-fuel Cell and reacts chemically to produce an electrical signal that is linearly proportional to the oxygen concentration in the sample gas. This electrochemical reaction is specific to oxygen and is unaffected by the presence of oxidizable gases (carbon monoxide, methane, hydrogen, etc.). The signal produced by the Micro-fuel Cell is electronically amplified and displayed on an analog or digital meter readout.

## LONG LIFE, RECHARGEABLE BATTERIES

The low operating power required by these units is supplied by two internally mounted, nickel cadmium batteries. Fully charged, these batteries supply enough capacity to operate the unit for approximately 30 days. An overnight charge once a month keeps these batteries in service for many years. An integral charging circuit and detachable power cord allow convenient charging.

## Features

- Three (TURBO2) or four (311/3110) linear ranges plus cal range
- High accuracy and sensitivity; fast response
- Unaffected by hydrocarbons and other oxidizable gases
- Ideal for measuring oxygen in hydrogen, nitrogen, argon, helium, acetylene, ethylene, butadiene, and many other gases
- Long-life, maintenance-free, Micro-fuel Cell oxygen sensor
- No support gases required
- Rugged, lightweight, and reliable

Model	Analysis	Meter	Certification
311XL	Trace	Analog	FM
311TCXL	Trace	Analog	BASEEFA
311	Trace	Analog	FM
311TC	Trace	Analog	CENELEC / BASEEFA
311PC	Percent	Analog	CENELEC / BASEEFA
3110	Trace	Digital	FM, CENELEC / BASEEFA
TurbO2	Trace	Analog	None
TurbO2P	Trace	Analog	None

## Applications

- Air separation and liquefaction
- Pure gaseous hydrocarbon stream monitoring
- Semiconductor manufacturing
- Protective atmosphere blanketing of primary liquid feedstocks and flammable liquids
- Process analysis of gaseous monomers – vinyl chloride, propylene, butadiene, isoprene, or ethylene
- Gas purity certification
- Glove box or pipeline leak detection
- Natural gas treatment and transmission
- Catalyst protection
- Inert gas welding of exotic metals
- Wave and reflow soldering
- Heat treating and bright annealing
- Nuclear fuel processing and isotope separation
- Analysis of chemical reactions
- Headspace gas analysis
- SF6 circuit breakers
- Crystal growth
- Plastics manufacturing

## Options

- 100 or 220 VAC operation
- Stainless steel quick disconnect gas fittings (female); mating set (3) of stainless-steel male fittings (vent, sample, calibration)
- Heavy plastic carrying case with foam interior (standard on Model 3110)
- Special ranges
- Stainless steel cell block (311 family only)
- Integral sample pump (TURBO2P)
- Insta Trace O2 sensor for Trace 311 series
- Real-time data-logging capabilities with digital output (Model 3110)
- Optional external pump (for non hazardous areas) (Model 3110)

The **Model 3110** represents the new generation of portable trace oxygen analysis capability for the natural gas industry. The 3110 combines a rugged, portable analyzer design with the high reliability of Teledyne trace level sensors.

This ensures highly accurate ppm oxygen readings in a variety of background gases -- including hydrocarbons. The batteries supply at least 100 hours of continuous power to the analyzer, with a low-battery indicator LED. The analyzer includes quick-disconnect fittings (to take measurements without hassle ) and can be equipped with an external sample system.

*The Model 3110 comes standard with a padded carrying case for extra protection.*

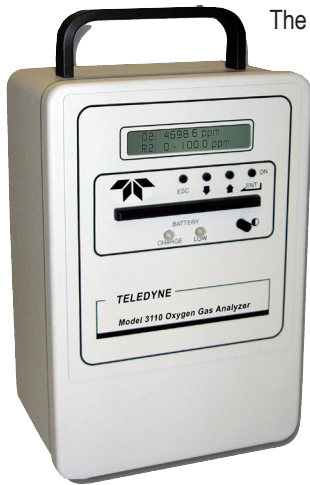

The **311XL and 311TCXL** are portable, intrinsically safe trace oxygen analyzers which can be operated without an external power source, providing analysis in decade steps ranging from 0-2 to 0-10,000 ppm full scale plus a special calibration range encompassing the known oxygen concentration of atmospheric air. The 311TCXL version is BASEEFA certified.\*

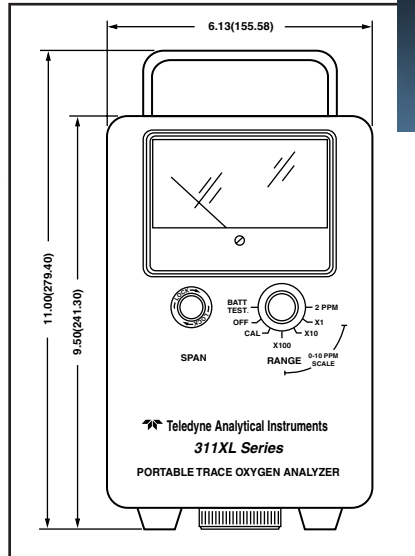

*Measurements are given in inches and millimeters. The instrument is 5 - 5/8" (142.8mm) deep.*



*The 311XL Series analyzes O2 in as low as the 0-2 ppm range.*



The **311 series** provides complete oxygen analysis in a compact package. Offering high accuracy and fast response, this unit is available in four different configurations. The 311 is the basic trace, battery powered unit. The 311TC and 311PC are trace and percent units that have received GENELEC approval.

The **TURBO2 and TURBO2P** are portable trace oxygen analyzers powered by rechargeable NiCAD batteries. Using the S-2 trace oxygen sensor, the TURBO2 series offers extremely quick recovery on general purpose trace applications from 0-100 to 0-10,000 ppm. For applications like solder reflow furnaces where the sample gas is not under pressure, the TURBO2P, with its built-in pump, can effectively draw the sample from the take-off to the analyzer.

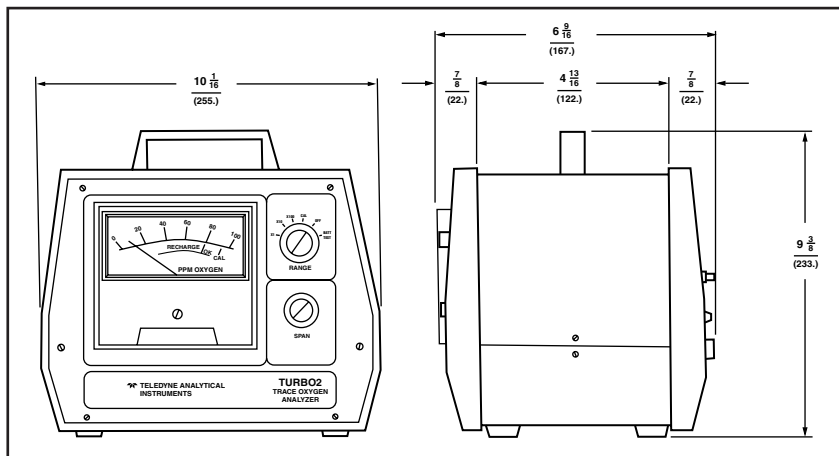

*Measurements are given in inches and millimeters.*



*The TURBO2 Series offers low cost, analog, trace O2 analysis.*

## Portable Oxygen Analyzers

	311XL & 311TCXL	311, 311TC & 311PC	TurbO2 & TurbO2P	3110
<b>Ranges</b>	0-2, 0-10, 0-100, 0-1000 ppm oxygen plus cal range for air calibration	Trace: 0-10, 0-100, 0-1000, 0-10,000 ppm oxygen plus cal range for air calibration Percent: 0-1, 0-2.5, 0-5, 0-10% oxygen plus calibration range	0-100, 0-1000, 0-10,000 ppm oxygen plus cal range for air calibration	Autoranging from 0-10 ppm to 0-25%
<b>Sensitivity</b>	20 ppb	0.5% of full scale	0.5% of full scale	
<b>Accuracy</b>	±2% of full scale (±5% of range in the 0-2 ppm range) at a constant 25°C temperature and constant pressure  ±5% (±10% of range in the 0-2 ppm range) over operating temperature range 0-35°C (once equilibrium has been achieved) at constant temperature	±2% of full scale (±1 ppm for 0-10 ppm range) at a constant temperature and pressure (temperature and pressure of calibration)  ±5% of full scale (±1 ppm for 0-10 ppm range) over operating temperature range (once temperature equilibrium has been achieved)	±2% of full scale at constant temperature and pressure  ±5% of full scale over operating temperature (once temperature equilibrium has been achieved)	
<b>Operating temperature</b>	32 to 95°F (0 to 35°C)	32 to 122°F (0 to 50°C)	32 to 122°F (0 to 50°C)	32 to 95°F (0 to 35°C)
<b>Response time</b>	90% in 5 to 10 seconds 90% in 60 seconds (0-10 ppm range) 90% in 90 seconds (0-2 ppm range) at 2.5 SCFH	90% in 5 to 10 seconds 90% in 60 seconds (0-10 ppm range)	90% of full scale in less than 10 seconds	90% in 61 seconds at 0-10 ppm range
<b>Reproducibility</b>	±1% at constant temperature	±1% at constant temperature	±1% at constant temperature	±1% at constant temperature
<b>Sensor type</b>	B-2CXL	B-2C (trace), B-1 (percent), others available	S-2	B-2C
<b>Power requirements</b>	AC power for battery recharge circuit of two current limited, rechargeable NiCad batteries, 110 VAC, 60 Hz (100 / 220 VAC, 50/60 Hz optional) 0.25 amps			
<b>Weight</b>	6 lbs. (2.71 kg)	6 lbs. (2.71 kg)	7 lbs. (3 kg)	6 lbs. (2.71 kg)
<b>Approvals</b>	Factory Mutual (FM), BASEEFA	Standard: Intrinsically safe (Class I, Division 1, Groups A, B, C, and D) Factory Mutual (FM) approved CENELEC: BASEEFA certified for EExibIICT4 intrinsically safe for zone 1 and 2; hydrogen, ethylene, oxide; temperature class - no surface temperatures above 135°C	None	Standard: Intrinsically safe (Class I, Division 1, Groups A, B, C, and D) Factory Mutual (FM) approved CENELEC: BASEEFA certified for EExibIICT4 intrinsically safe for zone 1 and 2; hydrogen, ethylene, oxide; temperature class - no surface temperatures above 135°C

### **TELEDYNE ANALYTICAL INSTRUMENTS**

A Teledyne Technologies Company

16830 Chestnut Street  
City of Industry, California 91748, USA

TEL: 626-934-1500 or 888-789-8168  
FAX: 626-934-1651 EMAIL: ask\_tai@teledyne.com

[www.teledyne-ai.com](http://www.teledyne-ai.com)

### Warranty

Instrument is warranted for 1 year against defects in material or workmanship

NOTE: Specifications and features will vary with application. The above are established and validated during design, but are not to be construed as test criteria for every product. All specifications and features are subject to change without notice.

